

OL 440-8-OH

Variable Ultraviolet Integrating Sphere Calibration Standard

The **OL 440-8-OH Variable Ultraviolet Integrating Sphere Calibration Standard** is large area, uniform, diffusely radiating source with a near normal integrated radiance that can be varied over several decades. The OL 440-8-OH consists of a forced air cooled source housing incorporating a deuterium lamp that is coupled to an 8-inch diameter integrating sphere coated with pressed PTFE. A micrometer-controlled aperture between the lamp and the 1-inch diameter input port of the integrating sphere allows continuous adjustment of the sphere intensity over the full useful range.

The in-line sphere port concept with an intermediate spider baffle provides for uniformity across the radiating aperture. A precision UV-enhanced silicon detector is mounted in the sphere wall and monitors the source intensity. An external radiometer, such as the OL 730C Programmable Radiometer/Photometer or equivalent, is utilized for readout of the integrated source radiance by measurement of the monitor detector current.

A shutter, located between the lamp and the entrance port of the integrating sphere, allows zeroing out the monitor detector without removing power to the lamp. The location of the shutter also ensures that any stray light (room light) entering the exit (radiating) port of the sphere is properly accounted for when zeroing the monitor detector. The sphere's exit (radiating) port has a 2.0-inch (50.8-mm) diameter aperture opening.

The OL 440-8-OH is provided with a spectral radiance calibration over the 200 nm to 400 nm region. The source is also available without calibration.

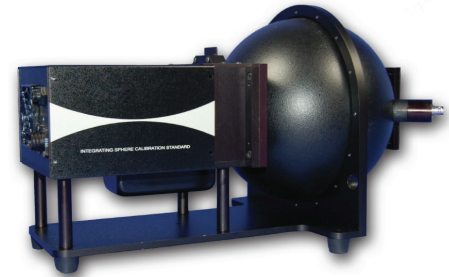

OL 440-8-OH OPTICS HEAD SPECIFICATIONS

Lamp Type Deuterium	30-Watt
Operating Current	300 milliamperes DC
Spectral Radiance Uncertainty <i>(Relative to NIST, k=2)</i>	±3% to 10% (350 – 400 nm) ±20% (200 – 240 nm)
Output Uniformity	±5% (1 Inch Dia) ¹ ±15% (Full Port) ¹
Monitor Stability	± 1% (After 30 Minutes Warm-up)
Sphere Coating (Reflectance)	73 – 99% (200 – 400 nm)
Sphere Monitor (Built-in)	UV-Enhanced Silicon Detector
Starting Voltage	350 VDC (Min.)
Anode Voltage	80 V ± 10%
Filament Starting Voltage	10 VDC (1.2 A)
Filament Operating Voltage	7 VDC (1.0 A)
Filament Prestart Warm-up Time	17 seconds
Optional Accessories	OL 46D Deuterium Lamp Power Supply ²

^{1/} Uniformity values are relative to the deviation from the average value of the points measured over the diameter specified.

^{2/} Requires modification of the OL 46D Power Supply to include an additional connector on the rear panel that supplies power to the 12 VDC fan in the OL 440-8-OH.

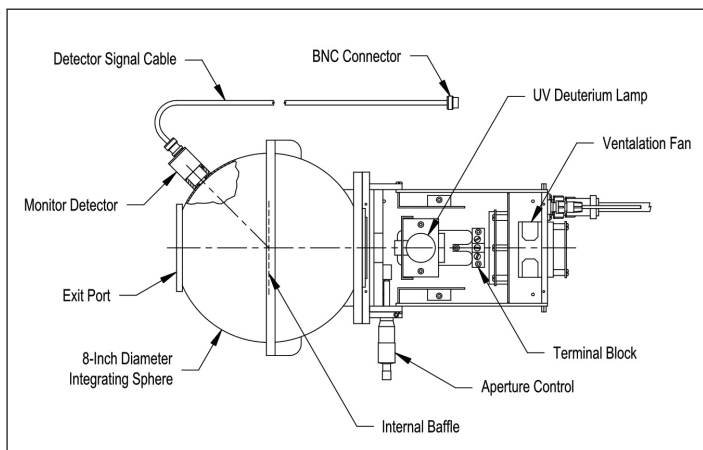

OL 440-8-OH Variable Ultraviolet Integrating Sphere Calibration Standard – Top View

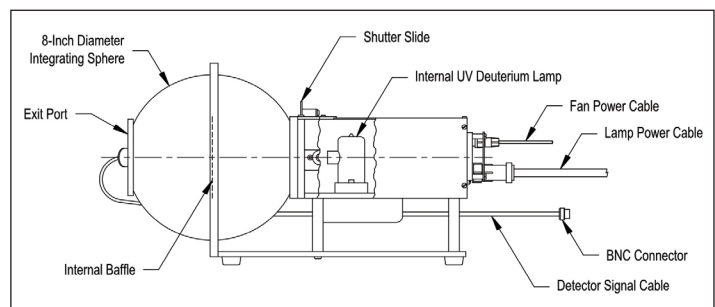

OL 440-8-OH Variable Ultraviolet Integrating Sphere Calibration Standard – Side View