

# OL 700-86VP

Vacuum Chuck LED Holder



The OL 700-86VP Vacuum Pump Assembly is designed to work in conjunction with the OL Series 700-86 Vacuum Chuck LED Holder to firmly secure surface-mount style LEDs onto the LED Holder.

The pump assembly is a complete unit consisting of a diaphragm pump, an adjustable pressure valve, a vacuum gauge, a vacuum line shut-off valve, and a quick-release hose connector all housed in a portable fan cooled enclosure. A 6-foot (1.8 meter) extension hose with the appropriate adapters is provided to help in placing the LED Holder in a remote location.

The vacuum pump contains a convoluted diaphragm in a unique pump cavity designed to provide extended life by minimizing stress, wear and heat buildup. The pump motor is totally enclosed, thermally protected and utilizes sealed ball bearings for long life. The adjustable pressure needle valve is used to select the proper vacuum pressure required to hold the LED being tested. Once set, the adjustment knob can be locked into place by using the locking ring. The vacuum gauge reading can be varied by using the adjustable pressure needle valve, and shows the amount of vacuum pressure applied to the LED Holder. It displays a vacuum value in inch-mercury (in Hg) units. The shut-off valve is a quarter-turn ball valve and is used to remove the vacuum from the LED Holder without having to readjust the needle valve or turn the pump off. The quick release hose connector is designed to accept and secure a hose adapter insert. The insert is o-ring sealed and locked into place when fully inserted into the connector.

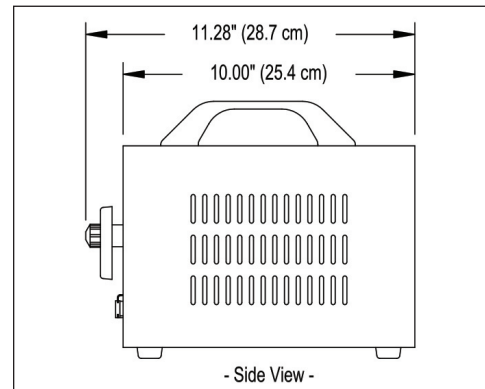
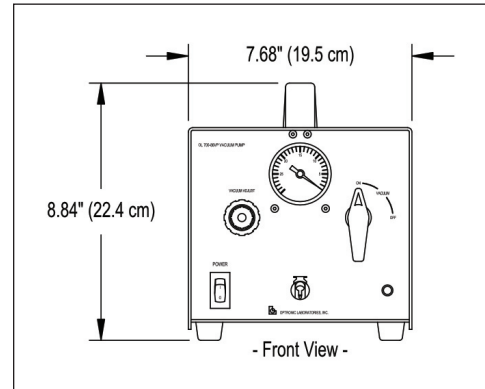

SPECIFICATIONS	
<b>Vacuum Range</b>	≥ 20 inches Hg ( <i>Intermittent or Continuous Duty</i> )
<b>Power</b>	115 VAC, 60 Hz, 2.0 A 230 VAC, 50 Hz, 1.0 A
<b>Dimensions</b>	8.84" x 7.68" x 10.00" (22.5 cm x 19.5 cm x 25.4 cm)
<b>Weight</b>	12 lbs. (5.4 kg)